

الاسم:  
الرقم:

مسابقة في: مادة الفيزياء  
المدة: ثلاث ساعات

**This exam is formed of four exercises in 4 pages.**  
**The use of a non-programmable calculator is recommended.**

**Exercise 1 (7.5 points)**

**Compound pendulum of a clock**

A clock, having a compound pendulum (S), can be equipped with a dry cell in order to function normally. The pendulum (S) of this clock consists of a rigid rod and a disk fixed from its lower end (Doc.1).

The pendulum can oscillate in the vertical plane about a horizontal axis ( $\Delta$ ) passing through the upper end O of the rod. The distance between O and the center of mass G of the pendulum is  $OG = a = 20$  cm.

Let  $G_0$  be the position of G when the pendulum is in its stable equilibrium position. The mass of (S) is  $m = 40$  g and its moment of inertia about ( $\Delta$ ) is  $I = 0.002$  kg.m<sup>2</sup>.

The pendulum is shifted from its equilibrium position by a small angle

$\theta_m = 10^\circ = 0.1745$  rad, and then it is released from rest at  $t_0 = 0$ .

(S) then oscillates about ( $\Delta$ ).

At an instant t, the position of the pendulum is denoted by its angular abscissa

$\theta = (\overrightarrow{OG_0}, \overrightarrow{OG})$  and its angular velocity is  $\theta' = \frac{d\theta}{dt}$ .

Take:

- the horizontal plane containing  $G_0$  as a reference level for gravitational potential energy;
- $g = 9.8$  m/s<sup>2</sup>;  $\cos \theta \cong 1 - \frac{\theta^2}{2}$  and  $\sin \theta \cong \theta$  (in rad), for  $\theta \leq 10^\circ$ .

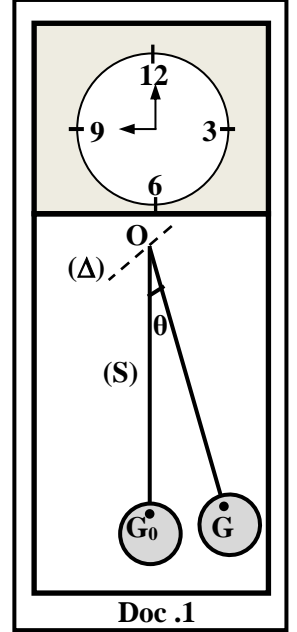

**1) Oscillations of (S) without a dry cell**

The clock is not equipped with a dry cell. Document (2) represents  $\theta$  as a function of time t.

- Determine, by using document 2, the mechanical energies  $ME_0$  at  $t_0 = 0$  and  $ME_1$  at  $t = t_1$  of the system [(S), Earth].
- Deduce that the pendulum is submitted to a friction force.
- Determine, between  $t_0$  and  $t_1$ , the average loss of the mechanical energy of the system [(S), Earth] during one oscillation.
- Specify the type of oscillation.
- Calculate the approximate value of the pseudo-period of (S) knowing that  $t_1 = 7.025$  s.
- The moment of the weight of (S) about ( $\Delta$ ) is  $\mathcal{M}_{mg}^- = -mg a \sin \theta$ . Show by applying the theorem

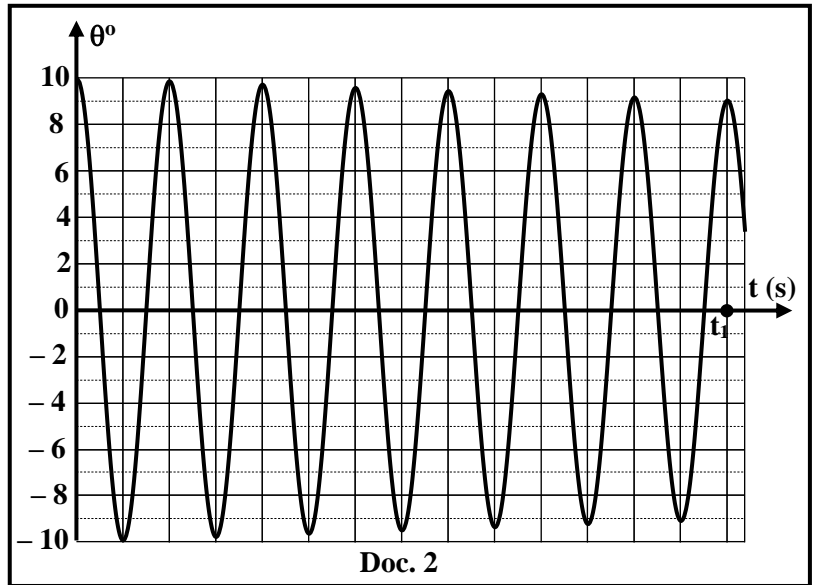

of angular momentum, to (S), that the moment of the friction force is:

$$\mathcal{M}_{f_r}^- = 0.002 \theta'' + 0.0784 \theta \quad (\text{SI}).$$

1-7) An appropriate system gives some values of:  $\theta$ ,  $\theta'$  and  $\theta'' = \frac{d\theta'}{dt}$  at certain instants as shown in the table below. Copy and complete the last three rows of the table.

t (s)	0	0.183	6.603	8.415	12.67
$\theta$ (rad)	0.1745	0.0714	-0.1284	-0.1306	-0.0747
$\theta''$ (rad/s <sup>2</sup> )	-6.8404	-2.7689	5.0153	5.1345	2.9042
$\theta'$ (rad/s)	0	-1	0.6	-0.5	0.8
$\mathcal{M}_{f_r}^-$ (N.m)	0		$-3.6 \times 10^{-5}$		$-4.8 \times 10^{-5}$
$\frac{\mathcal{M}_{f_r}^-}{\theta'}$ (N.m.s)	X				

1-8) Deduce the relation between  $\mathcal{M}_{f_r}^-$  and  $\theta'$ .

## 2) Oscillations of (S) with a dry cell

The clock is now equipped with a dry cell in order to compensate the loss in the mechanical energy of the system [(S), Earth], then the pendulum performs driven oscillations with constant amplitude of  $\theta_m = 10^\circ$  and of period  $T = 1$  s.

At  $t_0 = 0$ , the dry cell is fully charged and has a maximum energy of  $E_0 = 2880$  J. During a time interval  $\Delta t = t - t_0$  the dry cell furnishes 10% of  $E_0$  to the system [(S), Earth]. During this time interval, the clock functions normally (with a constant amplitude of  $\theta_m$ ).

2-1) Calculate the energy furnished by the dry cell to the system [(S), Earth] during the normal functioning of the clock.

2-2) Deduce, by using the result of part (1-3), the duration  $\Delta t$  (in days) during which the clock functions normally.

## Exercise 2 (8 points)

### Electric power consumed in an RLC circuit

We consider the electric circuit represented in document 3.

This circuit includes a capacitor of capacitance  $C = 2.5 \mu\text{F}$ , a coil of inductance  $L$  and resistance  $r$ , and a resistor of resistance  $R = 170 \Omega$ , all connected in series across an LFG, of adjustable frequency  $f$ . The LFG delivers an alternating sinusoidal voltage  $u_G = u_{DM} = U_m \sin(1250 t)$  (SI).

The circuit thus carries an alternating sinusoidal current  $i$ .

An oscilloscope, conveniently connected, allows us to display the voltage  $u_G = u_{DM}$  across the LFG on channel (Y<sub>1</sub>) and the voltage  $u_R = u_{NM}$  across the resistor on channel (Y<sub>2</sub>).

We obtain the waveforms (a) and (b) represented in document 4.

The vertical sensitivity on both channels is  $S_V = 5$  V/div.

Take  $0.32 \pi = 1$ .

- 1) Redraw the circuit of document 3 and show on it the connections of the oscilloscope.
- 2) Refer to document 4 to:
  - 2-1) show that waveform (a) represents  $u_G$ ;
  - 2-2) determine the maximum value  $I_m$  of  $i$ ;
  - 2-3) determine the phase difference  $\varphi$  between  $u_G$  and  $u_R$ .
- 3) Write down the expression of  $i$  as a function of time.
- 4) Show that the voltage across the capacitor is:

$$u_{DK} = u_C = -22.4 \cos\left(1250 t - \frac{\pi}{4}\right) \quad (\text{SI}).$$

- 5) Determine the expression of the voltage  $u_{KN} = u_{\text{coil}}$  across the terminals of the coil in terms of  $L$ ,  $r$  and  $t$ .

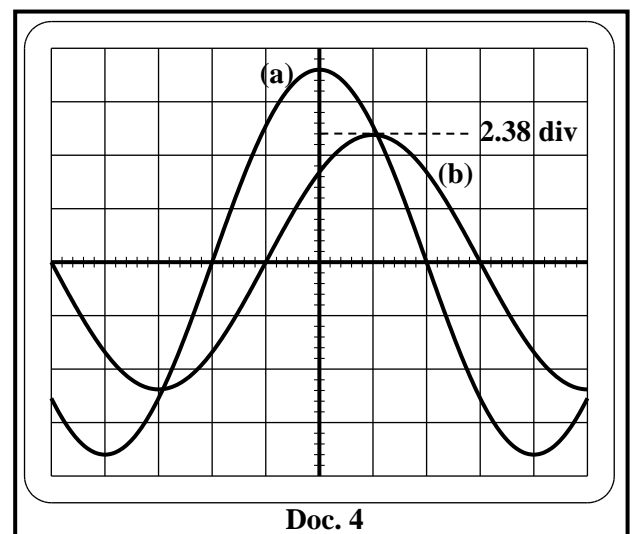
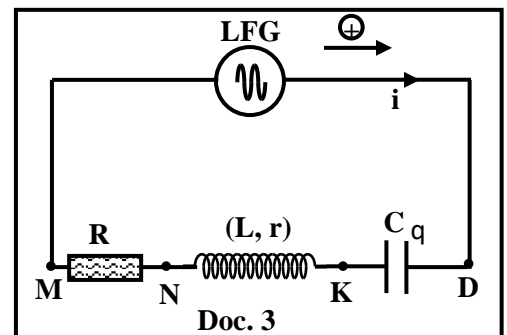

- 6) Show, by applying the law of addition of voltages and by giving the time  $t$  two particular values, that  $L = 0.4 \text{ H}$  and  $r = 10 \Omega$ .
- 7) The expression of the average electric power consumed in the circuit is:

$$P_{\text{average}} = \frac{(R + r)U_m^2}{2 \left[ (R + r)^2 + \left( L\omega - \frac{1}{C\omega} \right)^2 \right]}, \text{ with } \omega = 2\pi f.$$

The power  $P_{\text{average}}$  takes its maximum value  $P_1$  for a frequency  $f = f_1$ .

7-1) Determine the value of  $f_1$ .

7-2) Calculate the value of  $P_1$ .

7-3) The phenomenon of current resonance takes place for  $f = f_1$ . Justify.

7-4) Deduce the new expression of  $i$  as a function of time for  $f = f_1$ .

### Exercise 3 (7.5 points)

### Nuclear reactor

The first man-made nuclear reactor, or atomic pile as it was then known, in 1942 was the first step towards future nuclear power plants. The radioactive materials used in this reactor, such as uranium and plutonium, can be broken into several fragments under the impact of thermal neutrons. During this operation, other neutrons are emitted provoking in turn the splitting of new nuclei and releasing new neutrons and so on.

#### Doc. 5

- 1) Pick up from the text of document 5 the statement that refers to:

1-1) nuclear fission;

1-2) chain reaction.

- 2) One of the nuclear reactions that takes place inside a nuclear reactor is:

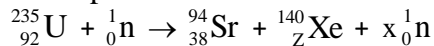

Given:  $1\text{u} = 931.5 \text{ MeV}/c^2$ ; Mass of neutron:  $m({}_0^1\text{n}) = 1.00866 \text{ u}$ .

Masses of nuclei:  $m({}_{92}^{235}\text{U}) = 234.99358 \text{ u}$ ;  $m({}_{38}^{94}\text{Sr}) = 93.90384 \text{ u}$ ;  $m({}_{54}^{140}\text{Xe}) = 139.90546 \text{ u}$ .

2-1) The fission reaction of uranium-235 is provoked. Why?

2-2) Calculate  $Z$  and  $x$ , indicating the used laws.

2-3) Determine, in MeV, the energy liberated by this reaction.

2-4) The kinetic energy of the emitted neutrons represents 2.6 % of the energy liberated by this reaction. Assume that all the emitted neutrons have equal kinetic energies. Calculate the kinetic energy of each emitted neutron.

- 3) Studies show that most of the emitted neutrons have high kinetic energy (few MeV). In order to provoke a new nuclear fission of a uranium nucleus-235, the neutron emitted by the fission reaction must have a low kinetic energy around  $E_{\text{th}} = 0.025 \text{ eV}$  (thermal neutron). In order to reduce the kinetic energy  $E_0$  of an emitted neutron to  $E_{\text{th}}$ , this neutron of mass  $m$  and speed  $V_0$ , must undergo successive collisions with heavier nuclei at rest of mass  $M = K m$  ( $K$  is a positive constant). We suppose that these collisions are elastic and all the velocities just before and after each collision are collinear.

3-1) Let  $V_1$  be the speed of the neutron just after its first collision with a heavy nucleus.

Show, using the laws of conservation of linear momentum and kinetic energy, that  $V_1 = \frac{(1-K)}{(1+K)} V_0$ .

3-2) Deduce that the expression of the kinetic energy  $E_n$  of this neutron just after the  $n^{\text{th}}$  collision is:

$$E_n = \left[ \frac{(1-K)^2}{(1+K)^2} \right]^n E_0.$$

3-3) If the initial kinetic energy of an emitted neutron is  $E_0 = 2.1 \text{ MeV}$ . Calculate the approximate number «  $n$  » of collisions needed for the final kinetic energy of this neutron to become

$E_n = 0.025 \text{ eV}$ , if it collides with:

3-3-1) deuterium nuclei ( $K = 2$ );

3-3-2) carbon nuclei ( $K = 12$ ).

3-4) The deuterium nuclei are more convenient than the carbon nuclei to slow down the neutron. Justify.

### Exercise 4 (7 points)

### Planck's constant

The aim of this exercise is to determine Planck's constant  $h$ .

**Given:**  $1 \text{ eV} = 1.6 \times 10^{-19} \text{ J}$ ; speed of light in air:  $c = 3 \times 10^8 \text{ m/s}$ .

#### 1) Interference

A source (S) emits a beam of monochromatic radiation of wavelength  $\lambda$  in air. The beam is incident normally in air on the two slits  $S_1$  and  $S_2$ , of Young's double slit experiment, which are at a distance of  $S_1S_2 = a = 0.5 \text{ mm}$ . The source (S) is placed on the perpendicular bisector of  $[S_1S_2]$ . A screen (E) is placed at distance  $D = 2 \text{ m}$  from the plane of the two slits. The perpendicular bisector of  $[S_1S_2]$  intersects (E) at point O. A sensor of electromagnetic waves is used to detect the interference fringes on (E).

The optical path difference at point M in the interference zone on the screen is

$$\delta = \frac{a x}{D}, \text{ where } x = \overline{OM} \text{ (Doc. 6).}$$

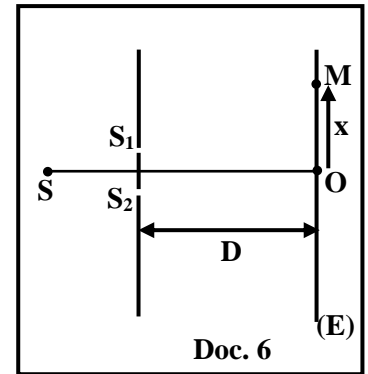

- 1-1) Determine the expression of the abscissa of the center of a fringe of maximum intensity and that of the center of a fringe of zero intensity in terms of  $\lambda$ ,  $D$ ,  $a$  and  $k$  ( $k$  is a whole number).
- 1-2) (S) emits a monochromatic radiation (1) of wavelength  $\lambda = \lambda_1$ . The abscissa of the center of the fifth fringe of maximum intensity is  $x = 30 \text{ mm}$ . Determine  $\lambda_1$  and deduce that the frequency of radiation (1) is  $\nu_1 = 2 \times 10^{14} \text{ Hz}$ .
- 1-3) (S) emits now a monochromatic radiation (2) of wavelength  $\lambda = \lambda_2$ . The abscissa of the center of the second fringe of zero intensity is  $x = 6 \text{ mm}$ . Determine  $\lambda_2$  and deduce that the frequency of radiation (2) is  $\nu_2 = 3 \times 10^{14} \text{ Hz}$ .

#### 2) Excitation and ionization of the hydrogen atom

The energy levels of the hydrogen atom are given by:

$$E_n = - \frac{13.6}{n^2} \text{ eV}; \text{ where } n \text{ is a non-zero positive integer.}$$

- 2-1) A hydrogen atom, initially in the energy level of  $n = 3$ , absorbs one of the photons of radiation (2) of frequency  $\nu_2$ . The hydrogen atom passes to the energy level of  $n = 7$ . Show that the energy of this photon is  $E_2 = 1.23 \text{ eV}$ .
- 2-2) A hydrogen atom, initially in the energy level of  $n = 7$ , absorbs one of the photons of radiation (1) of frequency  $\nu_1$ . The atom is ionized and the liberated electron has a kinetic energy of  $0.551 \text{ eV}$ . Show that the energy of this photon is  $E_1 = 0.82 \text{ eV}$ .

#### 3) Photoelectric effect

A metal of work function  $W_0 = 1.625 \text{ eV}$  is illuminated by radiation (3) of frequency  $\nu_3 = 5 \times 10^{14} \text{ Hz}$ .

The maximum kinetic energy of an electron extracted from the surface of the metal is  $0.445 \text{ eV}$ .

Determine the energy  $E_3$  of a photon of this radiation.

#### 4) Planck's constant

4-1) Using the previous results, show that:  $\frac{E_1}{\nu_1} \cong \frac{E_2}{\nu_2} \cong \frac{E_3}{\nu_3}$ .

- 4-2) Deduce, in SI, the value  $h$  of Planck's constant.

**Exercise 1 (7 points)**

**Compound pendulum of a clock**

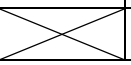
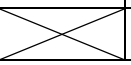
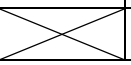
Part	Answer	Marks																		
1	$ME_0 = \frac{1}{2}I\theta'^2 + mga(1 - \cos\theta) = 0 + mga \frac{\theta_0^2}{2} = 0.04 \times 9.8 \times 0.2 \times \frac{(0.1745)^2}{2}$ Then , $ME_0 = 1.2 \times 10^{-3} \text{ J}$ <b>Or :</b> $ME_0 = \frac{1}{2}I\theta'^2 + mga(1 - \cos\theta) = 0 + 0.04 \times 9.8 \times 0.2 \times (1 - \cos 10^\circ)$ Then , $ME_0 = 1.19 \times 10^{-3} \text{ J}$ $ME_1 = 0 + mga \frac{\theta_1^2}{2} = 0.04 \times 9.8 \times 0.2 \times \frac{(0.157)^2}{2} = 0.966 \times 10^{-3} \text{ J}$ $ME_0 = \frac{1}{2}I\theta'^2 + mga(1 - \cos\theta) = 0 + 0.04 \times 9.8 \times 0.2 \times (1 - \cos 9^\circ)$ Then , $ME_1 = 0.965 \times 10^{-3} \text{ J}$	1.5																		
2	$ME_7 < ME_0$ , thus the pendulum (S) is submitted to a friction force	0.5																		
3	$ME_{\text{lost}} = \frac{ME_0 - Em_7}{7} = \frac{(1.2 \times 10^{-3}) - (0.966 \times 10^{-3})}{7} = 3.34 \times 10^{-5} \text{ J}$ <b>Or :</b> $ME_{\text{lost}} = \frac{Em_0 - Em_7}{7} = \frac{(1.19 \times 10^{-3}) - (0.965 \times 10^{-3})}{7} = 3.322 \times 10^{-5} \text{ J}$	1																		
4	The type is free damped oscillations, since the mechanical energy decreases.	0.25																		
5	$T = \frac{t_1}{n} = \frac{7.025}{7} = 1.0035 \text{ s} \cong 1 \text{ s}$	0.5																		
6	The forces acting on (S): the weight ( $m\vec{g}$ ) ; the support reaction at O ( $\vec{R}$ ) ; the friction force ( $\vec{f}_r$ ) $\sum \mathcal{M}_{\text{ext}} = \frac{d\sigma}{dt} = I\theta''$ , so $\mathcal{M}_{m\vec{g}} + \mathcal{M}_{\vec{R}} + \mathcal{M}_{\vec{f}_r} = I\theta''$ , then $-mga \sin\theta + 0 + \mathcal{M}_{\vec{f}_r} = I\theta''$ $\mathcal{M}_{\vec{f}_r} = 0.002\theta'' + (0.04 \times 9.8 \times 0.2 \times \theta)$ ; therefore, $\mathcal{M}_{\vec{f}_r} = 0.002\theta'' + 0.0784\theta$	1																		
7	<table border="1"> <tr> <td><math>\theta'</math>(rad/s)</td> <td>0</td> <td>- 1</td> <td>0.6</td> <td>- 0.5</td> <td>0.8</td> </tr> <tr> <td><math>\mathcal{M}_{\vec{f}_r}</math> (N.m)</td> <td>0</td> <td><math>6 \times 10^{-5}</math></td> <td><math>3.6 \times 10^{-5}</math></td> <td><math>3 \times 10^{-5}</math></td> <td><math>-4.8 \times 10^{-5}</math></td> </tr> <tr> <td><math>\frac{\mathcal{M}_{\vec{f}_r} \text{ (N.m)}}{\theta'}</math> S.I</td> <td></td> <td><math>-6 \times 10^{-5}</math></td> <td><math>-6 \times 10^{-5}</math></td> <td><math>-6 \times 10^{-5}</math></td> <td><math>-6 \times 10^{-5}</math></td> </tr> </table>	$\theta'$ (rad/s)	0	- 1	0.6	- 0.5	0.8	$\mathcal{M}_{\vec{f}_r}$ (N.m)	0	$6 \times 10^{-5}$	$3.6 \times 10^{-5}$	$3 \times 10^{-5}$	$-4.8 \times 10^{-5}$	$\frac{\mathcal{M}_{\vec{f}_r} \text{ (N.m)}}{\theta'}$ S.I		$-6 \times 10^{-5}$	$-6 \times 10^{-5}$	$-6 \times 10^{-5}$	$-6 \times 10^{-5}$	1
$\theta'$ (rad/s)	0	- 1	0.6	- 0.5	0.8															
$\mathcal{M}_{\vec{f}_r}$ (N.m)	0	$6 \times 10^{-5}$	$3.6 \times 10^{-5}$	$3 \times 10^{-5}$	$-4.8 \times 10^{-5}$															
$\frac{\mathcal{M}_{\vec{f}_r} \text{ (N.m)}}{\theta'}$ S.I		$-6 \times 10^{-5}$	$-6 \times 10^{-5}$	$-6 \times 10^{-5}$	$-6 \times 10^{-5}$															
8	$\mathcal{M}_{\vec{f}_r} = C \theta'$ , so $C = -6 \times 10^{-5} \text{ S.I}$ Therefore, $\mathcal{M}_{\vec{f}_r} = -6 \times 10^{-5} \theta'$	0.5																		
1	The furnished energy is : $E_{\text{furnished}} = 0.1E_0 = 0.1 \times 2880 = 288 \text{ J}$	0.5																		
2	$\left\{ \begin{array}{l} 1\text{s} \xrightarrow{\text{loss}} 3.34 \times 10^{-5} \text{ J} \\ \Delta t \xrightarrow{\text{loss}} 288 \text{ J} \end{array} \right\}$ , then $\Delta t = \frac{1 \times 288}{3.34 \times 10^{-5}} = 8.62 \times 10^6 \text{ s} = 99.76 \text{ days}$ <b>Or :</b> $1\text{s} \xrightarrow{\text{loss}} 3.322 \times 10^{-5} \text{ J}$ , then $\Delta t = \frac{1 \times 288}{3.322 \times 10^{-5}} = 8.669 \times 10^6 \text{ s} = 100.34 \text{ days}$ $\Delta t \xrightarrow{\text{loss}} 288 \text{ J}$	0.75																		

**Exercise 2 (8 points) Electric power in an RLC circuit**

Part	Answer	Marks
1		0.25
2	1 The vertical sensitivity is the same for both channels, and $U_{\max(a)} > U_{\max(b)}$ . Therefore, waveform (a) represents $u_g$	0.5
	2 $I_m = \frac{U_{R_{\max}}}{R} = \frac{2.38 \text{ div} \times 5 \text{ V/div}}{170} = 0.07 \text{ A}$	0.5
	3 $\varphi = \frac{2\pi \times 1 \text{ div}}{8 \text{ div}} = \frac{\pi}{4} \text{ rad}$	0.5
3	$i = I_m \sin(2\pi ft - \frac{\pi}{4}) = 0.07 \sin(1250t - \frac{\pi}{4})$ (i in A and t in s)	0.5
4	$u_{DK} = u_c = \frac{1}{C} \int i dt = \frac{1}{C} \int 0.07 \times \sin(1250t - \frac{\pi}{4}) dt = \frac{-0.07}{2.5 \times 10^{-6} \times 1250} \cos(1250t - \frac{\pi}{4})$ $u_{DK} = u_c = -22.4 \cos(1250t - \frac{\pi}{4})$	1
5	$U_{KN} = u_{\text{coil}} = ri + L \frac{di}{dt} = 0.07r \sin(1250t - \frac{\pi}{4}) + 0.07L \times 1250 \times \cos(1250t - \frac{\pi}{4})$ $U_{KN} = u_{\text{coil}} = 0.07r \sin(1250t - \frac{\pi}{4}) + 87.5L \cos(1250t - \frac{\pi}{4})$	1
6	$u_{DM} = u_{DK} + u_{KN} + u_{NM}$ $18 \sin(1250t) = -22.4 \cos(1250t - \frac{\pi}{4}) + 0.07r \sin(1250t - \frac{\pi}{4}) + 87.5L \cos(1250t - \frac{\pi}{4}) + 0.07 \times 170 \sin(1250t - \frac{\pi}{4})$ For $(1250t = \frac{\pi}{4} \text{ rad})$ : $18 \frac{\sqrt{2}}{2} = -22.4 + 87.5L$ ; therefore, $L = 0.4 \text{ H}$ For $(1250t = 0)$ : $0 = -22.4 \frac{\sqrt{2}}{2} - 0.07r \frac{\sqrt{2}}{2} + 87.5 \times 0.4 \times \frac{\sqrt{2}}{2} - 11.9 \frac{\sqrt{2}}{2}$ $0 = -22.4 - 0.07r + (87.5 \times 0.4) - 11.9$ Therefore, $r = 10 \Omega$	1.5
7	1 P takes its maximum value for: $(L\omega - \frac{1}{C\omega}) = 0$ , so $\omega = \frac{1}{\sqrt{LC}}$ , then $L\omega = \frac{1}{C\omega}$ , so $\omega^2 = \frac{1}{LC} = \omega_0^2$ Then, $f_2 = \frac{1}{2\pi\sqrt{LC}} = \frac{0.32}{2\sqrt{0.4 \times 2.5 \times 10^{-6}}} = 160 \text{ Hz}$	0.75
	2 $P_1 = \frac{U_m^2}{2(R+r)} = \frac{18^2}{2(170+10)} = 0.9 \text{ W}$	0.5
	3 Since $L\omega = 1/C\omega$ so $LC\omega^2 = 1$	0.25
	4 $I_m = \frac{U_m}{R+r} = \frac{18}{170+10} = 0.1 \text{ A}$ , then $i = 0.1 \sin(1000t)$	0.75

**Exercise 3 (7,5 points)**

**Nuclear reactor**

Part		Answer	Marks
1	1	Nuclear fission : . The radioactive materials used in this reactor, such as uranium and plutonium, can be broken into several fragments under the impact of thermal neutrons	0,25
	2	Chain reaction : other neutrons are emitted provoking in turn the splitting of new nuclei and releasing new neutrons and so on.	0,25
2	1	The reaction is provoked since the uranium nucleus is divided into two nuclei under the impact of a neutron. <b>Or:</b> The reaction takes place by an external intervention	0,25
	2	Low of conservation of mass number : $235 + 1 = 94 + 140 + x$ , then $x = 236 - 234 = 2$ Low of conservation of charge number : $92 = 38 + Z$ , then $Z = 54$	1
	3	$\Delta m = m_{\text{before}} - m_{\text{after}} = (m_U + m_n) - (m_{Sr} + m_{Xe} + 2m_n)$ $\Delta m = (234.99358 + 1.00866) - (93.90384 + 139.90546 + 3 (1.00866)) = 0.17562 \text{ u}$ $E_{\text{lib}} = \Delta m c^2 = 0.17562 \times 931.5 \frac{\text{MeV}}{c^2} \times c^2$ , then $E_{\text{lib}} = 163.59 \text{ MeV}$	1
	4	$2KE = \frac{2.6}{100} \times 163.59 = 4.25334 \text{ MeV}$ , then kinetic energy of each neutron is $KE = 2,127 \text{ MeV}$	0,75
3	1	Conservation of linear momentum : $m\vec{v}_0 = m\vec{v}_1 + K m\vec{v}$ $\vec{v}_0 = \vec{v}_1 + K\vec{v}$ , then $v_0 - v_1 = kv$ (Equation 1) The collision is elastic, then : $\frac{1}{2}mv_0^2 = \frac{1}{2}mv_1^2 + \frac{1}{2}Kmv^2$ $v_0^2 = v_1^2 + K v_1^2$ , so $(v_0 - v_1)(v_0 + v_1) = Kv^2$ (Equation 2) Dividing eq (2)by eq (1) gives: $(v_0 + v_1) = v$ , so $v_0 = v_1 + kv = v_1 + k(v_0 + v_1)$ Therefore, $v_1 = \frac{1-k}{1+k} v_0$	1,5
	2	Right after the first collision : $E_1 = \frac{1}{2} m v_1^2 = \frac{1}{2} m \left(\frac{1-k}{1+k}\right)^2 v_0^2 = \frac{(1-k)^2}{(1+k)^2} E_0$ Right after the $n^{\text{th}}$ collision : $E_n = \left(\frac{(1-k)^2}{(1+k)^2}\right)^n E$	1
	3	1 n = 8 or 9 collisions	0,5
	2	n = 54 or 55 collisions	0,5
4	The number of collisions needed to slow down a neutron is smaller if it collides with deuterium nuclei.	0,5	

**Exercise 4 (7 points)**

**Plancks constant**

Part		Answer	Marks
1	1	Center of a fringe of maximum intensity : $\delta = \frac{ax}{D} = k\lambda_1$ , then $x = \frac{k\lambda_1 D}{a}$	0,5
		Center of a fringe of zero intensity : $\delta = \frac{ax}{D} = (2k + 1) \frac{\lambda_1}{2}$ , then $x = \frac{(2k+1)\lambda_1 D}{2a}$	0,5
	2	The order of the fifth fringe of maximum intensity is $k = 5$ $x = \frac{5\lambda_1 D}{a}$ , then $\lambda_1 = 1,5 \times 10^{-6} \text{m}$ , thus $\nu_1 = \frac{c}{\lambda_1} = 2 \times 10^{14} \text{Hz}$	1
	3	The order of the second fringe of zero intensity is $k = 1$ , so $x = \frac{3\lambda_2 D}{2a}$ , then $\lambda_2 = 10^{-6} \text{m}$ , thus $\nu_2 = 3 \times 10^{14} \text{Hz}$	1
2	1	$E_2 = (E_7 - E_3) = \frac{-13.6}{49} + \frac{13.6}{9} = 1.23 \text{eV}$ .	0,75
	2	$E_1 = (E_\infty - E_7) + E_{\text{electron}} = (0 - \frac{13.6}{49}) + 0.551 = 0.82 \text{ eV}$	1
3		Einstein photoelectric equation : $E_{\text{photon } 3} = W_0 + E_{\text{cmax}}$ $E_{\text{photon } 3} = 1.625 + 0.445 = 2.07 \text{eV}$	0,75
4	1	$\frac{E_1}{\nu_1} = 4,1 \times 10^{-15} \text{ eV.s} = 6,56 \times 10^{-34} \text{ J.s}$ ; $\frac{E_2}{\nu_2} = 4,1 \times 10^{-15} \text{ eV.s} = 6,56 \times 10^{-34} \text{ J.s}$ ; $\frac{E_3}{\nu_3} = 4,14 \times 10^{-15} \text{ eV.s} = 6,62 \times 10^{-34} \text{ J.s}$ Then , $\frac{E_1}{\nu_1} \cong \frac{E_2}{\nu_2} \cong \frac{E_3}{\nu_3}$	0,75
	2	$E = h\nu$ , then $h \cong 6.6 \times 10^{-34} \text{ J.s}$	0,75