

الاسم:
الرقم:

مسابقة في مادة الفيزياء
المدّة: ثلاث ساعات

This exam is formed of four exercises in four pages
The use of non-programmable calculators is recommended

Exercise 1 (7 1/2 pts)

Rolling of a disk along a vertical string

A vertical thin string is fixed to a ceiling from its top end while the other end is wound around a uniform homogeneous disk of center of mass (G), radius R and mass $m = 2 \text{ kg}$ (Doc. 1).

Ox is a vertical axis oriented positively downward and of origin O.

At $t_0 = 0$, the disk is released from rest, (G) coincides with O and at a height $h = 2.7 \text{ m}$ from a horizontal line (AB).

(G) moves then in rectilinear motion along the x-axis and the disk rotates, with an angular speed θ' around its horizontal axis (Δ) passing through O.

During the motion the string remains tangent to the disk. Neglect air resistance.

The aim of this exercise is to determine the speed and the acceleration of (G)

when it passes through the line (AB) by two different methods.

Given:

- the horizontal plane containing (AB) is a reference level for gravitational potential energy;
- the linear speed of (G), at an instant t, is $v = R \theta'$;
- the moment of inertia of the disk about (Δ) is $I = \frac{mR^2}{2}$;
- $g = 10 \text{ m/s}^2$.

1- First method: Newton's second law

The disk is acted upon by two forces: its weight $m\vec{g}$ and the tension \vec{T} of the string (Doc. 1).

1-1) Determine, with respect to (Δ), the expression of the moment of \vec{T} and the value of the moment of $m\vec{g}$.

1-2) Apply Newton's second law of rotation (theorem of the angular momentum) to prove that

$$T = \frac{I\theta''}{R} \quad [\theta'' \text{ is the angular acceleration of the disk with respect to } (\Delta)].$$

1-3) Apply Newton's 2nd law of translation to prove that $T = mg - ma$ [\vec{a} is the acceleration of (G)].

1-4) Show that $a = \frac{2g}{3}$.

1-5) Deduce, in terms of g and t, the expression of:

- 1-5-1)** the speed v of (G);
- 1-5-2)** the abscissa x of (G).

1-6) Determine the speed of (G) when it passes through the line (AB).

2- Second method: principle of conservation of the mechanical energy

2-1) Calculate the mechanical energy of the system [disk, Earth] at $t_0 = 0$.

2-2) Write, in terms of v, m, θ' and I, the expression of the mechanical energy of the system [disk, Earth] when (G) passes through the line (AB).

2-3) Apply the principle of the conservation of the mechanical energy to determine the speed of (G) when it passes through the line (AB).

2-4) Write the expression of the mechanical energy of the system [disk, Earth] at any instant t in terms of v, m, θ' , I, g, h and the abscissa x of (G).

2-5) Deduce that $a = \frac{2g}{3}$.

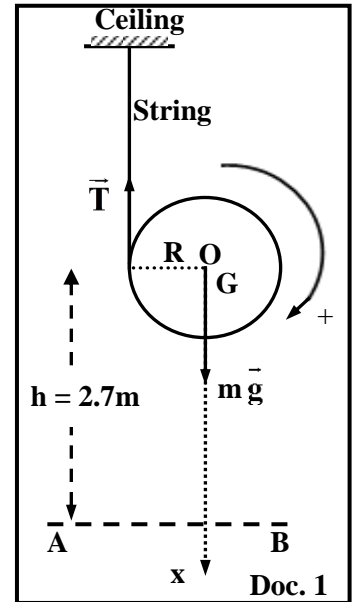

Exercise 2 (7 pts)

Fission of uranium-235

In a nuclear power plant uranium-235 captures a thermal neutron; it forms a new unstable nucleus ${}^A_Z\text{X}$ (Reaction 1).

${}^A_Z\text{X}$ is divided into two nuclei krypton and barium (possible fission fragments) with an emission of certain number of neutrons and γ -radiation (Reaction 2).

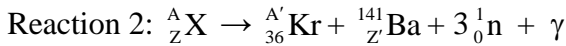
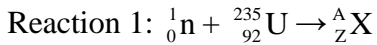

Given:

the mass of ${}^{235}_{92}\text{U}$ nucleus is 234.99346 u;

the mass of ${}^{A'}_{36}\text{Kr}$ nucleus is 91.90641 u;

the mass of ${}^{141}_Z\text{Ba}$ nucleus is 140.88369 u;

the mass of ${}^1_0\text{n}$ is 1.00866 u;

1 u = 931.5 MeV/c²;

1 eV = 1.6 × 10⁻¹⁹ J.

1- Determine the values of A, Z, A', and Z'.

2- Deduce the name of the isotope ${}^A_Z\text{X}$.

3- The overall equation (fission reaction) of the above reactions is:

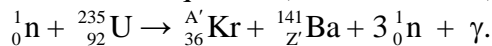

This fission reaction leads to a chain fission reaction. Why?

4- At least one of the fission fragments is born in the excited state. Why?

5- Show that the energy liberated by the fission of one uranium-235 is $E_{\text{lib}} \cong 2.8 \times 10^{-11}$ J.

6- The first fission reaction gives off 3 neutrons (first generation). Suppose that the three neutrons stimulate other fissions similar to the above one. These fissions in turn give off 9 neutrons (second generation), and so on....

6-1) Determine the number N of neutrons given off by the 100th generation.

6-2) Suppose that each one of the above emitted neutrons bombards one uranium-235 nucleus.

Deduce the total energy released due to the fission of uranium-235 nuclei bombarded by the above N neutrons.

6-3) In a nuclear power plant, the fission reaction is controlled: on average only one of three neutrons produced by each fission is allowed to stimulate another fission reaction.

Suppose that a nuclear power plant operates according to the above fission reaction and has an efficiency of 33 %. In the nuclear reactor, 1.5×10^{25} uranium-235 nuclei undergo fission during one day.

6-3-1) Determine the electric energy E_{elec} delivered by this station during one day.

6-3-2) Deduce the average electric power P_{elec} of the station.

7- Once fusion nuclear reaction started it is difficult to control. Deduce one advantage of fission nuclear reaction over fusion nuclear reaction.

Exercise 3 (8 pts)

Thermal energy released by electric circuits

The aim of this exercise is to determine the thermal energy released by two different electric circuits.

The circuit of document 2 is composed of:

an ideal battery of voltage $E = 10 \text{ V}$, a resistor of resistance $R = 100 \Omega$, a coil of inductance L , two switches K_1 and K_2 , and a capacitor of capacitance $C = 5 \mu\text{F}$.

The two channels (Ch1 and Ch2) of an oscilloscope are connected across the terminals of the coil and that of the resistor respectively.

The "INV" button of the oscilloscope is pressed.

Initially, K_1 and K_2 are open; the capacitor and the coil have no energies.

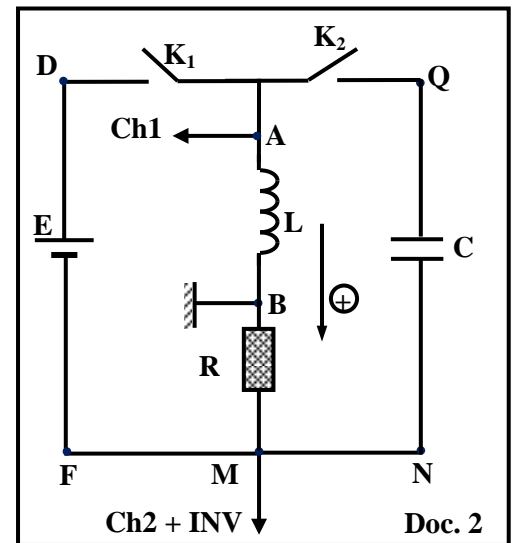

1- Determination of the thermal energy released by RL series circuit

We close K_1 at an instant $t_0 = 0$. The curves of document 3 represent $u_{\text{coil}} = u_{AB}$ and $u_R = u_{BM}$ as functions of time t .

The straight line (Δ) is tangent to $u_R(t)$ at $t_0 = 0$.

1-1) During the growth of the current, the magnetic energy stored in the coil increases. Justify.

1-2) Referring to document 3, indicate the value of the voltage across the coil at the steady state.

1-3) Deduce that the coil has negligible resistance.

1-4) Derive the differential equation that describes the variation of u_R as a function of time t .

1-5) Use the differential equation to determine $\frac{du_R}{dt}$ in terms of R , L and E , at the instant $t_0 = 0$.

1-6) Show that $L = 0.5 \text{ H}$ by using the tangent (Δ).

1-7) Determine the maximum magnetic energy W_{mag} stored in the coil.

1-8) The steady state is attained at $t = 25 \text{ ms}$, the thermal energy released by the resistor during the time interval $[0, 25 \text{ ms}]$ is $W_R = 7 W_{\text{mag}}$.

1-8-1) Calculate W_R during the time interval $[0, 25 \text{ ms}]$.

1-8-2) Determine the thermal energy released by the resistor during the interval $[0, 30 \text{ ms}]$.

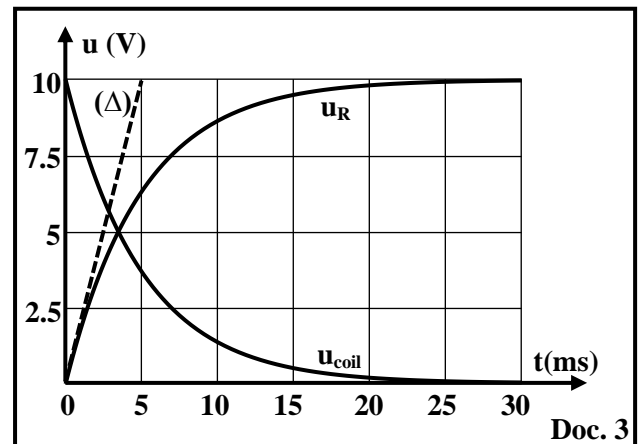

2- Determination of the thermal energy released by RLC series circuit

When the steady state in the circuit is attained, we close K_2 and open K_1 simultaneously at an instant taken as a new initial instant $t_0 = 0$. The graph of document 4, shows $u_R = u_{BM}$ and $u_{\text{coil}} = u_{AB}$ as functions of time t .

2-1) Give, at $t_0 = 0$, the initial electromagnetic energy stored in the RLC circuit.

2-2) At an instant $t_1 = 22.5 \text{ ms}$:

$u_{\text{coil}} = u_{AB} = -3.125 \text{ V}$. (Doc. 4)

2-2-1) Use document 4 to specify the value of the current in the circuit at the instant t_1 .

2-2-2) Apply the law of addition of voltages to determine $u_{NQ} = u_C$ at the instant t_1 .

2-2-3) Determine the electromagnetic energy in this circuit at t_1 .

2-2-4) Deduce the thermal energy released by this circuit during the time interval $[0, 22.5 \text{ ms}]$.

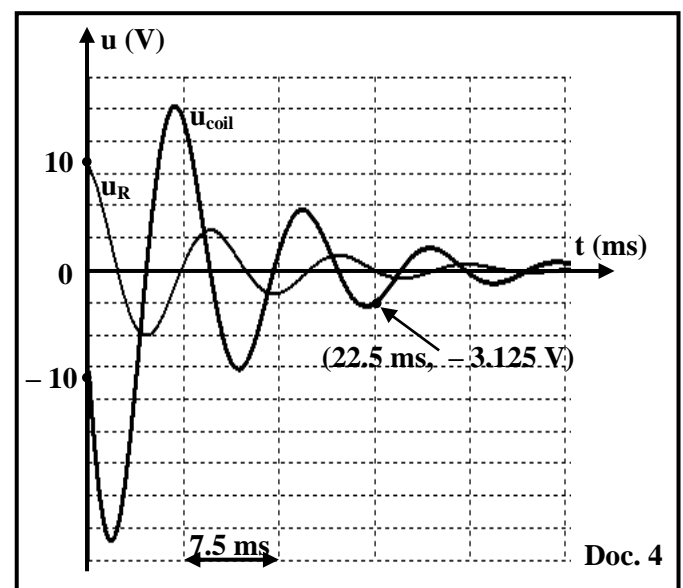

Exercise 4 (7 1/2 pts)

Interference of light

Document 5 represents the set-up of Young's double slit experiment. The vertical screen (E) is movable and remains parallel to an opaque plate (P) containing two horizontal and parallel thin slits S_1 and S_2 separated by a distance $S_1S_2 = a$.

S is a thin horizontal slit placed at a distance d from (P).

D is the distance between (E) and (P).

M, N and O, are three points on (E) belonging to a vertical axis (Ox).

O is the midpoint of [MN] and equidistant from S_1 and S_2 .

A laser light of wavelength λ in air illuminates the thin slit S.

Given:

$SS_1 = SS_2$; $\lambda = 600 \text{ nm}$; $a = 0.1 \text{ mm}$; $MN = 30 \text{ mm}$; $d = 20 \text{ cm}$.

The abscissa of the point N is $x_N = 15 \text{ mm}$.

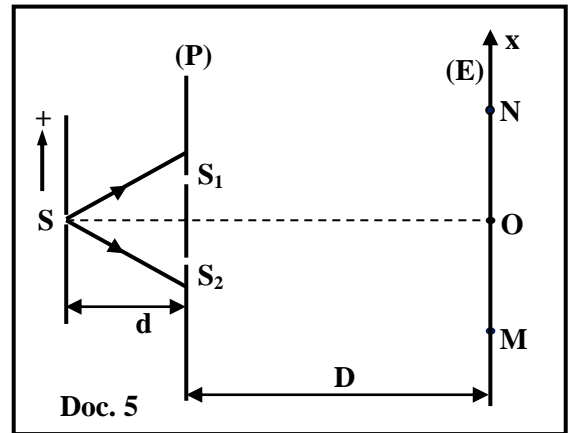

1- Qualitative study

- 1-1) The conditions of interference are satisfied. Why?
- 1-2) Name the phenomenon that takes place at each of S_1 and S_2 .
- 1-3) The fringes on (E) are directed along the horizontal. Why?

2- Experimental study

The optical path difference at any point Q, on the interference pattern in the screen, having an abscissa

$$x = \overline{OQ} \text{ is: } \delta = (SS_2 + S_2Q) - (SS_1 + S_1Q) = \frac{ax}{D} .$$

- 2-1) In the interference region, the point O is the center of a bright fringe for any value of D. Justify.
- 2-2) The distance between (P) and (E) is $D = D_1 = 3 \text{ m}$.
 - 2-2-1) Define the interfringe distance "i" and calculate its value.
 - 2-2-2) Deduce that between M and N there is only one bright fringe of center O.
- 2-3) Now the distance between (P) and (E) is $D = D_2 = 5 \text{ m}$.
 - 2-3-1) Show that the point N is a center of a dark fringe.
 - 2-3-2) We move gradually the screen (E) towards (P) parallel to itself. For a distance $D = D_3$, the point N becomes the center of the first bright fringe. Calculate D_3 .
- 2-4) We displace the slit S by a displacement z in a direction parallel to (P) towards the side of one of the two slits.

The optical path difference, at the point N, becomes: $\delta' = \frac{az}{d} + \frac{ax_N}{D} .$

- 2-4-1) Determine the relation between z and D so that N remains the center of the first bright fringe.
- 2-4-2) Deduce the value of the displacement z if $D = 2 \text{ m}$.
- 2-4-3) Indicate then the direction of the displacement of (S).

مسابقة في مادة الفيزياء
أسس التصحيح

Exercise 1 (7.5 points) Rolling of a disk along a vertical string				
Part	Answer	Mark		
1	1-1	$\mathcal{M}_{m\vec{g}} = 0$ since $m\vec{g}$ passes through (Δ) . $\mathcal{M}_{\vec{T}} = T \times R$.	0.5	
	1-2	$\Sigma \mathcal{M}_{\text{ext}} = \frac{d\sigma}{dt} = I \theta''$, then $\mathcal{M}_{m\vec{g}} + \mathcal{M}_{\vec{T}} = 0 + TR$, then $TR = I \theta''$; therefore, $T = \frac{I \theta''}{R}$	0.5	
	1-3	$\Sigma \vec{F}_{\text{ext}} = m\vec{a}$; $m\vec{g} + \vec{T} = m\vec{a}$. Projection along Ox, We obtain : $mg - T = ma$ Then, $T = mg - ma$	0.75	
	1-4	$T = \frac{I \theta''}{R} = \frac{mR^2 a}{2R^2} = \frac{ma}{2}$ But $T = mg - ma$, then $mg = \frac{ma}{2} + ma = \frac{3ma}{2}$, Therefore, $a = \frac{2g}{3}$	0.5	
	1-5	1	Primitive of the acceleration we obtain $v = a t + V_0$ Then, $v = \frac{2g}{3} t$ ($V_0 = 0$)	0.5
		2	Primitive of the speed we obtain $x = \frac{1}{2} \frac{2g}{3} t^2 = \frac{g}{3} t^2$	0.5
1-6	$h = \frac{g}{3} t^2$; $t = \sqrt{\frac{3h}{g}} = \sqrt{\frac{3 \times 2.7}{10}}$, then $t = 0.9$ S $v = \frac{2g}{3} t = \left(\frac{2g}{3} \times 0.9\right) + 0 = \frac{2 \times 10}{3} \times 0.9 = 6$ m/s	1		
2	2-1	$ME_0 = KE + GPE = 0 + mgh = 2 \times 10 \times 2.7 = 54$ J	0.5	
	2-2	$ME_f = \frac{1}{2} mv^2 + \frac{1}{2} I \theta'^2 + 0$	0.5	
	2-3	$ME_0 = ME_f$, $54 = \frac{1}{2} \left(mv^2 + \frac{mR^2 v^2}{2R^2} \right) = \frac{1}{2} \left(\frac{3mV^2}{2} \right)$ Then, $v = \sqrt{\frac{4 \times 54}{3 \times 2}} = 6$ m/s	1	
	2-4	$ME = \frac{1}{2} mv^2 + \frac{1}{2} I \theta'^2 + mg(h - x)$	0.5	
	2-5	$\frac{1}{4} mR^2 \theta'^2 = -mgh + mgx - \frac{1}{2} mv^2 + mgh$ ($E_{m(t)} = E_{m_0}$) $\frac{1}{4} mR^2 \frac{v^2}{R^2} + \frac{1}{2} mv^2 = mgx$; $\frac{3}{4} mv^2 = mgx$; $v^2 = \frac{4gx}{3}$ Differentiate both sides with respect to time, so $2vv' = \frac{4g}{3} x'$ Therefore, $a = \frac{2g}{3}$	0.75	

Exercise 2 (7 pts)		Fission of uranium-235	
Part		Answer	Mark
1		Law of conservation of charge number : $Z = 92 + 0 = 92$. Law of conservation of mass number : $A = 235 + 1 = 236$. $236 = A' + 141 + 3(1)$, alors $A' = 92$. $92 = 36 + Z' + 3(0)$, then $Z' = 56$	1
2		A_ZX is uranium since $Z = 92$.	0.25
3		Since each fission reaction liberates 3 neutrons.	0.5
4		Since γ radiation is emitted	0.25
5		$E_{\text{lib}} = \Delta m c^2$ $\Delta m = m_{\text{before}} - m_{\text{after}}$ $= [1.00866 + 234.99346]$ $- [140.88369 + 91.90641 + 3(1.00866)] = 0.18604 \text{ u}$ $E_{\text{lib}} = \Delta m c^2 = 0.18604 \times 931.5 \frac{\text{MeV}}{c^2} \times c^2 = 173.3 \text{ Mev}$ $E_{\text{lib}} = 173.3 \times 1.6 \times 10^{-13}$, so $E_{\text{lib}} \cong 2.8 \times 10^{-11} \text{ J}$	1.5
6	6-1	1 generation $\rightarrow 3^1$ neutrons. 2 generations $\rightarrow 3^2 = 9$ neutrons ... 100 th generations $\rightarrow N = 3^{100} = 5.15 \times 10^{47}$ neutrons	0.5
	6-2	$E_{\text{total}} = N E_{\text{lib}} = 5.15 \times 10^{47} \times 2.8 \times 10^{-11} = 1.44 \times 10^{37} \text{ J}$	0.5
	6-3	$E_{\text{nucleaire}} = 1.5 \times 10^{25} \times E_{\text{lib}} = 1.5 \times 10^{25} \times 2.8 \times 10^{-11}$ $= 4.2 \times 10^{14} \text{ J}$ $E_{\text{electrical}} = 0.33 \times E_{\text{nuclear}} = 0.33 \times 4.2 \times 10^{14}$ $= 1.39 \times 10^{14} \text{ J}$	1
	2	$P_{\text{electrical}} = \frac{E_{\text{electrical}}}{\Delta t} = \frac{1.39 \times 10^{14}}{24 \times 3600} = 1.6 \times 10^9 \text{ W}$	1
7		The released energy by fission nuclear reaction can be controlled so it can be used in nuclear power plant, while fusion nuclear reaction cannot be controlled so it cannot be used in nuclear power plant.	0.5

Exercise 3 (8 pts) Thermal energy consumed by an electric circuit				
Part	Answer	Mark		
1	1-1	u_R increases then i increases, $W_{\text{mag}} = \frac{1}{2} L i^2$, i increases, then W_{mag} increases.	0.5	
	1-2	$u_{\text{coil}} = 0$	0.25	
	1-3	$u_{\text{coil}} = r i + L \frac{di}{dt}$. Steady state: $u_{\text{coil}} = 0$ et $\frac{di}{dt} = 0$ (since u_R is constant than i is constant) and $i \neq 0$, so $r = 0$	0.25	
	1-4	$u_{DE} = u_{AB} + u_{BM}$; $E = L \frac{di}{dt} + u_R$. $u_R = iR$, then, $\frac{di}{dt} = \frac{1}{R} \frac{du_R}{dt}$, then $\frac{du_R}{dt} + \frac{R}{L} u_R = \frac{R}{L} E$	0.75	
	1-5	At $t_0 = 0$; $u_R = 0$, then at $t_0 = 0$: $\frac{du_R}{dt} = \frac{RE}{L}$	0.5	
	1-6	The slope of the tangent to u_R at $t_0 = 0$, $= \frac{du_R}{dt}$ So slope $= \frac{10}{0.005} = \frac{RE}{L}$, so $L = \frac{100 \times 10 \times 0.005}{10} = 0.5H$	0.75	
	1-7	$W_{\text{max}} = \frac{1}{2} L I_{\text{max}}^2 = \frac{1}{2} \times 0.5 \times \left(\frac{10}{100}\right)^2 = 2.5 \times 10^{-3}J$	0.75	
	1-8	1 $W_R = 7 W_{\text{mag}} = 7 \times 2.5 \times 10^{-3} = 17.5 \times 10^{-3} J$ 2 $W_{\text{heat}[0, 30 \text{ ms}]} = W_{\text{heat}[0, 25 \text{ ms}]} + W_{\text{heat}[25 \text{ ms}, 30 \text{ ms}]}$ $= 7 \times 2.5 \times 10^{-3} + EI_{\text{max}} \Delta t = 17,5 \times 10^{-3} + (10 \times 0.1 \times 0.005)$ Then, $W_{\text{heat}[0, 30 \text{ ms}]} = 22.5 \times 10^{-3}J$	0.5 1	
2	2-1	$W_{\text{em}} = \frac{1}{2} Li^2 + \frac{1}{2} Cu_C^2$ at $t_0 = 0$. $u_C = 0$, Then, $W_{\text{em}} = \frac{1}{2} Li^2 = \frac{1}{2} \times 0.5 \times (0,1)^2 = 2.5 \times 10^{-3}J$	0.75	
	2-2	1	At $t = 22.5\text{ms}$; $u_R = 0$, then $i = 0$	0.25
		2	$u_{AB} + u_{BM} + u_{MN} + u_{NQ} + u_{QA} = 0$, then, $u_{\text{coil}} + u_R + 0 + u_C + 0 = 0$, so $-3.125 + 0 + u_C = 0$, then $u_C = 3.125 V$	0.5
		3	$W'_{\text{em}} = \frac{1}{2} Li^2 + \frac{1}{2} Cu_C^2 = 0 + \frac{1}{2} \times 5 \times 10^{-6} \times 3.125^2$ $= 2.44 \times 10^{-5}J$	0.75
		4	$W_{\text{heat}[0, 22.5 \text{ ms}]} = W_{\text{em}} - W'_{\text{em}} = 2.5 \times 10^{-3} - 2.44 \times 10^{-5}$ $= 2.47 \times 10^{-3}J$	0.5

Exercise 4 (7.5 pts) Interference of light				
Part	Answer	Mark		
1	1-1	The two slits are illuminated by the same source.	0.5	
	1-2	Diffraction	0.5	
	1-3	The fringes on (E) are directed along the horizontal because The slits are directed along the horizontal and fringes are parallel to the slits.	0.5	
2	2-1	At O: $\delta = \frac{a \times 0}{D} = 0$ for every value of D. Therefore, O is the center of the central bright fringe every value of D <u>Or</u> $\delta = (SS_2 + S_2O) - (SS_1 + S_1O) = (SS_2 - SS_1) + (S_2O - S_1O) = 0 + 0 = 0$ Since : $SS_2 = SS_1$ et $S_1O = S_2O$	0.5	
	2-2	1	The interfringe i is the distance between the centers of two consecutive fringes of same nature. $i = \frac{\lambda D}{a} = \frac{600 \times 10^{-9} \times 3}{0.1 \times 10^{-3}} = 18 \times 10^{-3} \text{ m} = 18 \text{ mm}$	1
		2	$OM = ON = \frac{30}{2} = 15 \text{ mm} < i$. Therefore, between N and M we have only one bright fringe at O.	0.5
	2-3	1	$\delta_N = \frac{ax}{D} = (2k+1) \frac{\lambda}{2}$, Then, $(2k+1) = \frac{2ax}{D\lambda} = \frac{2 \times 0.1 \times 15 \times 10^{-6}}{5 \times 600 \times 10^{-9}} = 1$, thus $k = 0$ <u>OR:</u> $i' = \frac{\lambda D}{a} = \frac{600 \times 10^{-9} \times 5}{0.1 \times 10^{-3}} = 30 \times 10^{-3} = 30 \text{ mm}$ $x_N = 15 \text{ mm} = \frac{i'}{2}$, then N is the center of the first dark fringe. <u>Or</u> $\frac{\delta}{\lambda} = \frac{ax}{D\lambda} = \frac{x}{i'}$, so $\delta = \frac{1}{2} \lambda$ has the form $(2k+1) \frac{\lambda}{2}$ with $K = 0$ then N is the center of the first dark fringe	0.5
		2	For the first bright fringe, $\delta = k\lambda = \lambda$ ($k = 1$) $k\lambda = \frac{ax}{D_3}$; $D_3 = \frac{ax}{\lambda} = \frac{10^{-4} \times 15 \times 10^{-3}}{600 \times 10^{-9}} = \frac{15}{6} = 2.5 \text{ m}$	0.75
		2-4	1	$\delta' = \frac{az}{d} + \frac{ax_N}{D} = k\lambda = \lambda$ $\frac{az}{d} = -\frac{ax_N}{D} + \lambda$; $z = -\frac{d}{D}x_N + \frac{\lambda D}{a} = \frac{-3 \times 10^{-3}}{D} + 1.2 \times 10^{-3}$
2	$z = \frac{-3 \times 10^{-3}}{2} + 1.2 \times 10^{-3} = -0.3 \times 10^{-3} \text{ m}$		0.5	
3	$z < 0$; then, S is moved downward.		0.5	