

الاسم:
الرقم:

مسابقة في مادة الفيزياء
المدة: ثلاث ساعات

This exam is formed of four exercises in four pages
The use of non-programmable calculators is recommended

مسابقة في مادة الفيزياء

المدة: ثلاث ساعات

(باللغة الانكليزية)

الاسم:

الرقم:

Exercise 1 (7 1/2 pts)

Rolling of a disk along a vertical string

A vertical thin string is fixed to a ceiling from its top end while the other end is wound around a uniform homogeneous disk of center of mass (G), radius R and mass $m = 2 \text{ kg}$ (Doc. 1). Ox is a vertical axis oriented positively downward and of origin O.

At $t_0 = 0$, the disk is released from rest, (G) coincides with O and at a height $h = 2.7 \text{ m}$ from a horizontal line (AB).

(G) moves then in rectilinear motion along the x-axis and the disk rotates, with an angular speed θ' around its horizontal axis (Δ) passing through O.

During the motion the string remains tangent to the disk. Neglect air resistance.

The aim of this exercise is to determine the speed and the acceleration of (G) when it passes through the line (AB) by two different methods.

Given:

- the horizontal plane containing (AB) is a reference level for gravitational potential energy;
- the linear speed of (G), at an instant t , is $v = R \theta'$;
- the moment of inertia of the disk about (Δ) is $I = \frac{mR^2}{2}$;
- $g = 10 \text{ m/s}^2$.

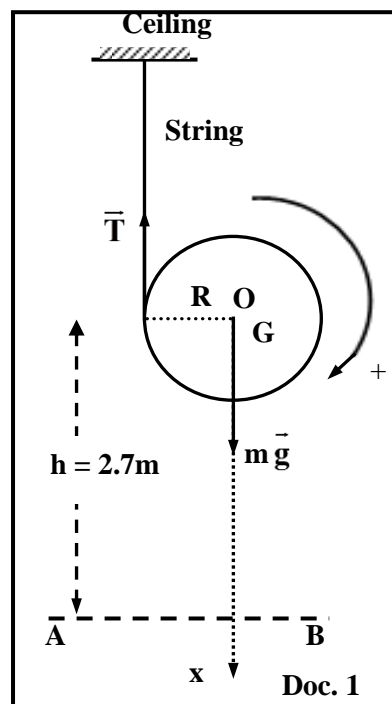

1- First method: Newton's second law

The disk is acted upon by two forces: its weight $m\vec{g}$ and the tension \vec{T} of the string (Doc. 1).

1-1) - Determine, with respect to (Δ) , the expression of the moment of \vec{T}

- Determine, with respect to (Δ) , the value of the moment of $m\vec{g}$.

1-2) Prove that $T = \frac{I\theta''}{R}$ [θ'' is the angular acceleration of the disk with respect to (Δ)].

By applying Newton's second law of rotation (theorem of the angular momentum) to

1-3) Prove that $T = mg - ma$ [\vec{a} is the acceleration of (G)].

By Applying Newton's 2nd law of translation to

1-4) Show that $a = \frac{2g}{3}$.

1-5) Deduce, in terms of g and t , the expression of:

1-5-1) the speed v of (G);

1-5-2) the abscissa x of (G).

1-6) Determine the speed of (G) when it passes through the line (AB).

2- Second method: principle of conservation of the mechanical energy

2-1) Calculate the mechanical energy of the system [disk, Earth] at $t_0 = 0$.

2-2) Write, in terms of v , m , θ' and I , the expression of the mechanical energy of the system [disk, Earth] when (G) passes through the line (AB).

2-3) determine the speed of (G) when it passes through the line (AB). By applying the principle of the conservation of the mechanical energy.

2-4) Write the expression of the mechanical energy of the system [disk, Earth] at any instant t in terms of v , m , θ' , I , g , h and the abscissa x of (G).

2-5) Deduce that $a = \frac{2g}{3}$.

Exercise 2 (7 pts)

Fission of uranium-235

In a nuclear power plant uranium-235 captures a thermal neutron; it forms a new unstable nucleus ${}^A_Z\text{X}$ (Reaction 1).

${}^A_Z\text{X}$ is divided into two nuclei krypton and barium (possible fission fragments) with an emission of certain number of neutrons and γ -radiation (Reaction 2).

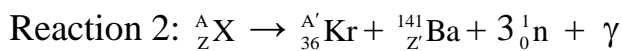
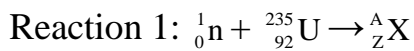

Given:

the mass of ${}^{235}_{92}\text{U}$ nucleus is 234.99346 u;

the mass of ${}^{A'}_{36}\text{Kr}$ nucleus is 91.90641 u;

the mass of ${}^{141}_{Z'}\text{Ba}$ nucleus is 140.88369 u;

the mass of ${}^1_0\text{n}$ is 1.00866 u;

$$1 \text{ u} = 931.5 \text{ MeV}/c^2;$$

$$1 \text{ eV} = 1.6 \times 10^{-19} \text{ J}.$$

1- Determine the values of A, Z, A', and Z'.

2- Deduce the name of the isotope ${}^A_Z\text{X}$.

3- The overall equation (fission reaction) of the above reactions is:

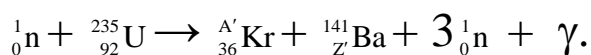

This fission reaction leads to a chain fission reaction. **Why?**

4- At least one of the fission fragments is born in the excited state. **Why?**

5- Show that the energy liberated by the fission of one uranium-235 is $E_{\text{lib}} \cong 2.8 \times 10^{-11} \text{ J}$.

6- The first fission reaction gives off 3 neutrons (first generation).

Suppose that the three neutrons stimulate other fissions similar to the above one.

These fissions in turn give off 9 neutrons (second generation), and so on....

6-1) Determine the **number N** of neutrons given off by the 100th generation.

6-2) Deduce the total energy released due to the fission of uranium-235 nuclei bombarded by the above N neutrons. Suppose that each one of the above emitted neutrons bombards one uranium-235 nucleus.

6-3) In a nuclear power plant, the fission reaction is controlled: on average only one of three neutrons produced by each fission is allowed to stimulate another fission reaction. Suppose that a nuclear power plant operates according to the above fission reaction and has an **efficiency of 33 %**. In the nuclear reactor, 1.5×10^{25} uranium-235 **nuclei undergo fission** during one day.

6-3-1) Determine the electric energy E_{elec} delivered by this station during one day.

6-3-2) Deduce the average electric power P_{elec} of the station.

7- Once fusion nuclear reaction started it is difficult to control.

Deduce one advantage of fission nuclear reaction over fusion nuclear reaction.

Exercise 3 (8 pts)

Thermal energy released by electric circuits

The aim of this exercise is to determine the thermal energy released by two different electric circuits.

The circuit of document 2 is composed of:

an ideal battery of voltage $E = 10 \text{ V}$, a resistor of resistance $R = 100 \Omega$, a coil of inductance L , two switches K_1 and K_2 , and a capacitor of capacitance $C = 5 \mu\text{F}$.

The two channels (Ch1 and Ch2) of an oscilloscope are connected across the terminals of the coil and that of the resistor respectively. The "INV" button of the oscilloscope is pressed.

Initially, K_1 and K_2 are open; the capacitor and the coil have no energies.

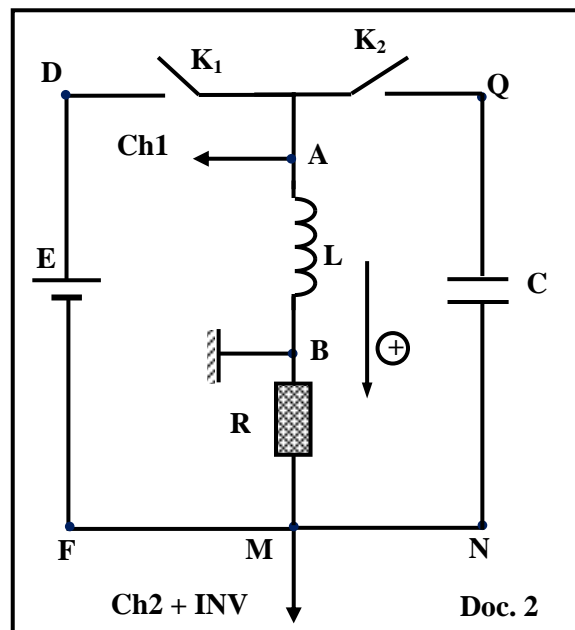

Part 1 : Determination of the thermal energy released by RL series circuit

We close K_1 at an instant $t_0 = 0$. The curves of document 3 represent $u_{\text{coil}} = u_{AB}$ and $u_R = u_{BM}$ as functions of time t .

The straight line (Δ) is tangent to $u_R(t)$ at $t_0 = 0$.

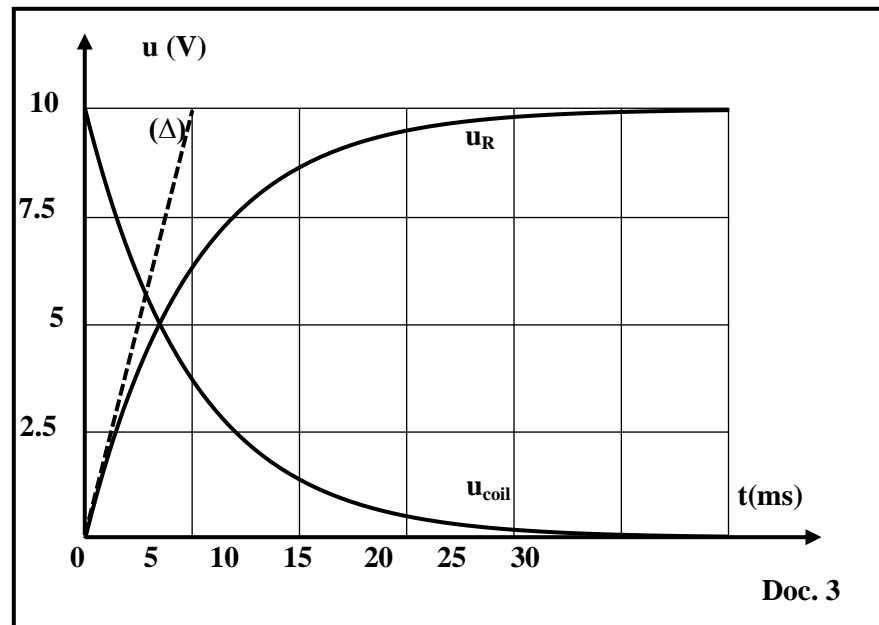

1-1) Justify that the magnetic energy stored in the coil increases during the growth of the current,

1-2) Indicate the value of the voltage across the coil at the steady state. Referring to document 3,

1-3) Deduce that the coil has negligible resistance.

1-4) Derive the differential equation that describes the variation of u_R as a function of time t .

1-5) Determine $\frac{du_R}{dt}$ in terms of R , L and E , at the instant $t_0 = 0$. using the differential equation.

1-7) Show that $L = 0.5 \text{ H}$ by using the tangent (Δ) .

1-7) Determine the maximum magnetic energy W_{mag} stored in the coil.

1-8) The steady state is attained at $t = 25 \text{ ms}$, the thermal energy released by the resistor during the time interval $[0, 25 \text{ ms}]$ is

$$W_R = 7 W_{\text{mag}}.$$

1-8-1) Calculate W_R during the time interval $[0, 25 \text{ ms}]$.

1-8-2) Determine the thermal energy released by the resistor during the interval $[0, 30 \text{ ms}]$.

1- Determination of the thermal energy released by RLC series circuit

When the steady state in the circuit is attained, we close K_2 and open K_1 simultaneously at an instant taken as a new initial instant $t_0 = 0$. The graph of document 4, shows $u_R = u_{BM}$ and $u_{\text{coil}} = u_{AB}$ as functions of time t .

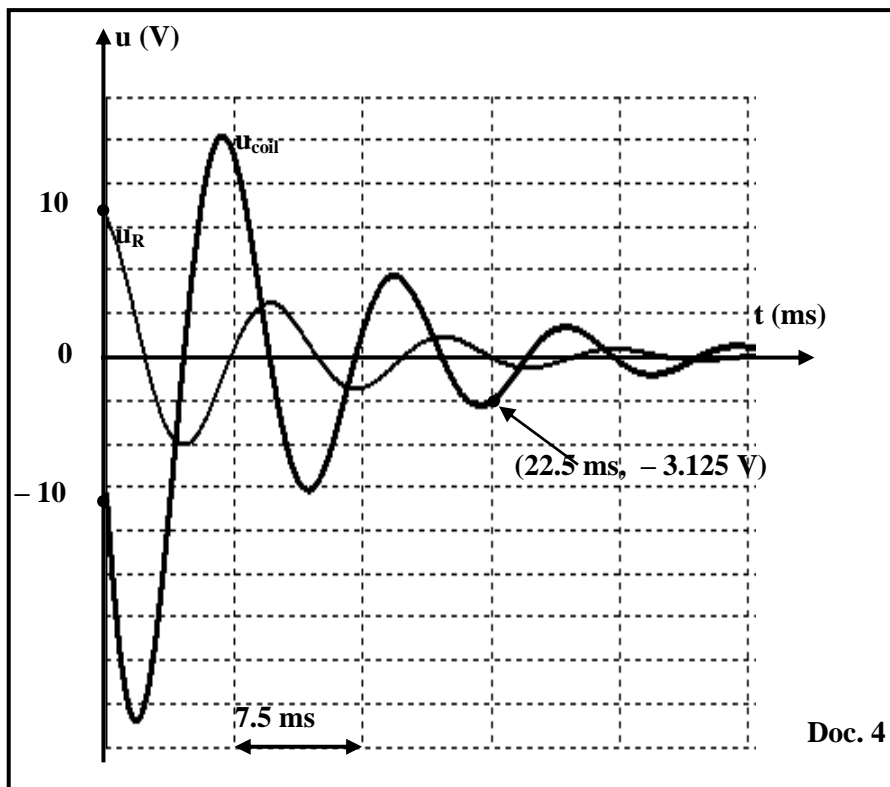

2-1) Give, at $t_0 = 0$, the initial electromagnetic energy stored in the RLC circuit.

2-2) At an instant $t_1 = 22.5$ ms:

$$u_{\text{coil}} = u_{\text{AB}} = - 3.125 \text{ V. (Doc. 4)}$$

2-2-1) Use document 4 to **specify** the value of the current in the circuit at the instant t_1 .

2-2-2) determine $u_{\text{NQ}} = u_{\text{C}}$ at the instant t_1 by applying the law of addition of voltages.

2-2-3) Determine the electromagnetic energy in this circuit at t_1 .

2-2-4) Deduce the thermal energy released by this circuit during the time interval $[0, 22.5 \text{ ms}]$.

Exercise 4 (7 ½ pts)

Interference of light

Document 5 represents the set-up of Young's double slit experiment. The vertical screen (E) is movable and remains parallel to an opaque plate (P) containing two horizontal and parallel thin slits S_1 and S_2 separated by a distance $S_1S_2 = a$.

S is a thin horizontal slit placed at a distance d from (P).

D is the distance between (E) and (P).

M, N and O, are three points on (E) belonging to a vertical axis (Ox).

O is the midpoint of [MN] and equidistant from S_1 and S_2 .

A laser light of wavelength λ in air illuminates the thin slit S.

Given:

$SS_1 = SS_2$; $\lambda = 600 \text{ nm}$; $a = 0.1 \text{ mm}$; $MN = 30 \text{ mm}$; $d = 20 \text{ cm}$.

The abscissa of the point N is $x_N = 15 \text{ mm}$.

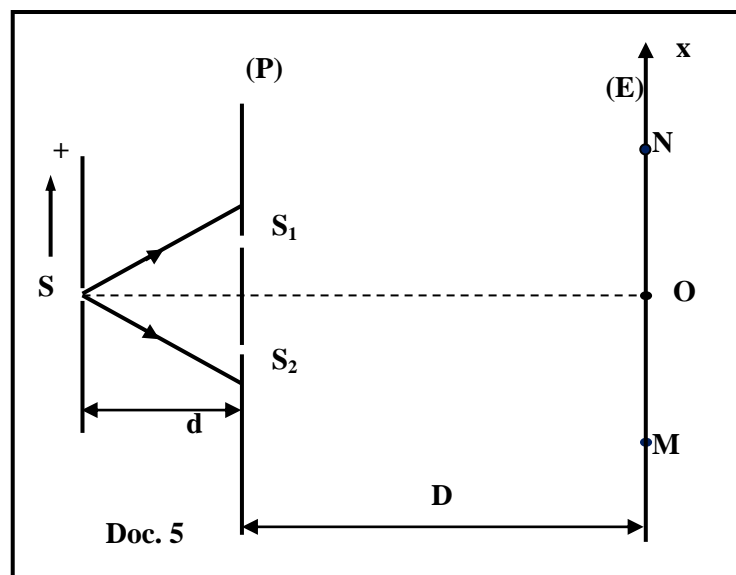

1- Qualitative study

1-1) The conditions of interference are satisfied. **Why?**

1-2) **Name** the phenomenon that takes place at each of S_1 and S_2 .

1-3) The fringes on (E) are directed along the horizontal. **Why?**

2- Experimental study

The optical path difference at any point Q, on the interference pattern in the screen, having an abscissa

$$x = \overline{OQ} \text{ is: } \delta = (SS_2 + S_2Q) - (SS_1 + S_1Q) = \frac{ax}{D} .$$

2-1) In the interference region, **Justify** that the point O is the center of a bright fringe for any value of D.

2-2) The distance between (P) and (E) is **D = D₁ = 3 m**.

2-2-1) Define the interfringe distance "i" and calculate its value.

2-2-2) Deduce that between M and N there is only one bright fringe of center O.

2-3) Now the distance between (P) and (E) is **D = D₂ = 5 m**.

2-3-1) Show that the point N is a center of a dark fringe.

2-3-2) We **move** gradually the screen (E) towards (P) **parallel** to itself. For a distance **D = D₃**, the point N becomes the center of the first bright fringe. **Calculate** D₃.

2-4) We displace the slit S by a displacement z in a direction parallel to (P) towards the side of one of the two slits. The optical path difference, at the point N, becomes:

$$\delta' = \frac{az}{d} + \frac{ax_N}{D} .$$

2-4-1) Determine the relation between z and D so that N remains the center of the first bright fringe.

2-4-2) Deduce the value of the displacement z if **D = 2 m**.

2-4-3) Indicate then the direction of the displacement of (S).